



CLOSING INSTRUCTIONS FOR UN 1H1 TIGHTHEAD DRUMS AND 3H1 JERRICANS

ETS-CD-1012

Version 1.0

Issued 03-June-2011



STATEMENT OF NOTIFICATION REQUIREMENTS

These instructions are provided by BWAY Corporation to the filler of UN certified plastic packaging marketed under the BWAY, NAMPAC or ICL brand names in accordance with §178.2(c) of the U.S. Department of Transportation's (DOT) hazardous materials regulations, Title 49 of the Code of Federal Regulations (CFR). The instructions apply exclusively to 1H1 and 3H1 single unit packaging of the type and style as described herein and bearing a UN certification marking. At the time of transfer, any package or packaging component supplied by BWAY does not meet the UN standard because it is disassembled. Only when assembled in the manner, and using the components described herein, is this packaging certified by BWAY to meet the UN standard.

It is the regulatory obligation of the packaging filler to properly assemble and close UN certified packaging. If the packaging is not assembled and closed per these instructions, or if any of the components are omitted or replaced with substitute components, this packaging is not certified by BWAY as meeting the UN performance standard. It is the regulatory obligation of the shipper to determine that the filled package is authorized for transportation. When transporting by air, the general requirements for transportation by aircraft in §173.27 of Title 49 CFR must also be met.

APPLICABLE BWAY UN 1H1 and 3H1 COMPONENTS

The instructions found in this closure document are applicable to the following BWAY molded plastic containers and their associated closures.

1H1 ROUND TIGHTHEAD DRUM:

- UN Rated Round tighthead drum (15 gallon and below)

3H1 SQUARE, RECTANGLE and DELEX JERRICANS:

- UN Rated (NA-Series) Square tighthead (7 Gallon and below)
- UN Rated (NA-Series) Rectangle tighthead (6 Gallon and below)
- UN Rated (NA-Series) Delex tighthead (20 Liter and below)

CLOSURES:

- 51mm Screw Cap (4 TPI)
- 61mm Screw Cap (4 TPI)
- 63mm Screw Cap (8 TPI)
- 70mm Screw Cap with Gasket (6 TPI & 8 TPI)
- 70 mm with Gore Vent (8 TPI)
- Crimp-On Pour Spouts
- American Flange Tab Seal Pour Spout (Crimp-On)
- 2 inch Internal Buttress Bung Plug
- 2 Inch Internal Buttress Bung Plug with microporous vent

VENTS:

- 3/4" bung plug
- 3/4" plug vents with membrane
- 3/4" Acorn vents
- 18mm vent
- 22mm vent
- 28mm vent

51, 61, 63 and 70mm Screw Cap Closure Instructions

PURPOSE:

To ensure that the threaded screw cap is properly sealed when assembled onto BWAY's jerricans and tighthead drums. The DOT/UN Performance Certification only applies to a Tight Head Container that is closed per this procedure.

SIGNIFICANCE:

The sealing performance of the Cap is compromised if the top surface of the neck is rough, has a burr, or is not clean; in addition, if the gasket in the cap is not properly seated in the O-Ring groove, twisted, or is not clean. The Caps are only to be assembled on the jerrican after all sealing surfaces pass inspection.

APPARATUS:

- 51, 61, 63 or 70mm Torque Head Fixture
- Torque Wrench (Adjustable from 10 - 15 ft-lbs or 120 - 180 in-lbs)
- The use of a calibrated automatic torque application machine is permissible if it does not damage the threads or seating surface of the container.

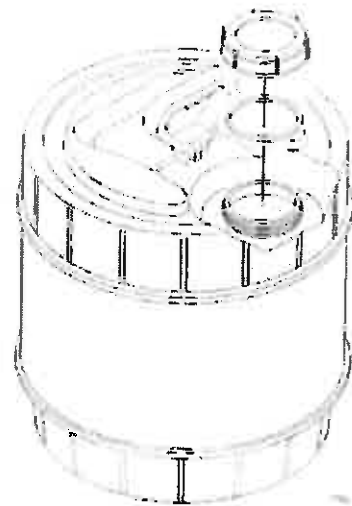
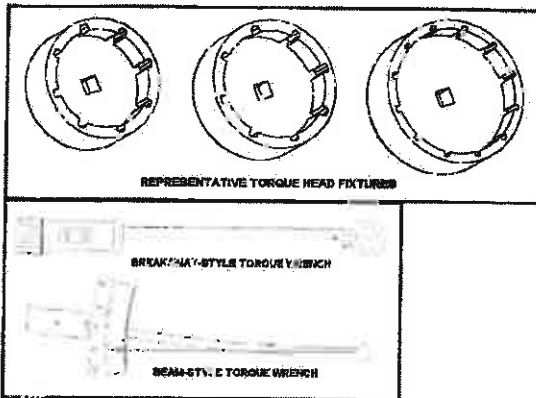

PROCEDURE:

1. Inspect the top surface of the neck to ensure an acceptable sealing surface, clean and free of any debris.
2. Inspect the cap to ensure the gasket is properly assembled and is clean.
3. Start the cap on the neck by hand, rotating the cap in a clock-wise direction. Take care not to cross thread the cap; this will result in damage to the cap or to the neck finish.
4. Using the 51, 61, or 70mm torque head fixture mounted onto a torque wrench, tighten the cap per the table below.

CAP SIZE (DIA)	Thread Pitch	INSTALLATION TORQUE
51mm	6mm (4TPI)	180 IN-LBS (15 FT-LBS)
61mm	6mm (4TPI)	180 IN-LBS (15 FT-LBS)
63mm	8TPI (3mm)	120 IN-LBS (10 FT-LBS)
70mm	8TPI (3mm)	120 IN-LBS (10 FT-LBS)
70mm	6TPI (4mm)	150 IN-LBS (12.5 FT-LBS)

2" Buttress Bung Plug Closure Instructions

PURPOSE:

These instructions are designed to ensure the proper installation of any one of several 2" buttress threaded bung plugs into BWAY jerricans and tighthead drums. The UN Regulated Container Certification applies to marked UN 1H1 and 3H1 Tight Head packages that are closed per this procedure.

SIGNIFICANCE:

The sealing performance of the Bung Plug can be compromised if the top gasket sealing surface of the neck is rough, has a burr, or is not clean; in addition, if the gasket on the Bung Plug is not properly seated in the O-Ring groove, is twisted, or is not clean. The Bung Plugs are only to be assembled on the jerrican after all sealing surfaces have passed Visual inspection.

APPARATUS:

- o Torque wrench of suitable measuring capacity (25 ft-lbs minimum), digital breakaway style preferred
- o Torque Wrench Fitting specific to the bung plug being installed. Fitting should be shape matched to and fit securely inside the center impression in the bung plug and mount directly to the torque wrench shaft. Contact the specific bung plug manufacturer for additional Torque Wrench Fitting information.
- o The use of a calibrated automatic torque application machine is permissible if it does not damage the threads or seating surface of the container.

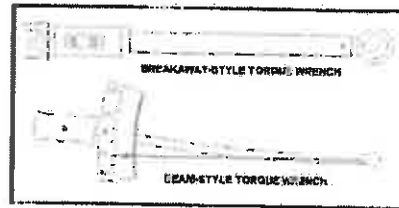
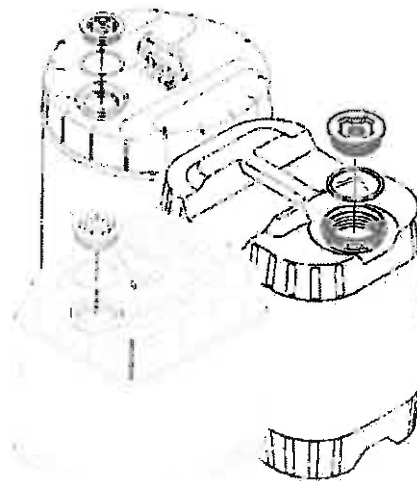

ASSEMBLY INSTRUCTIONS:

1. Verify that the top sealing surface of the container neck is clean and free of defects or debris. Clean as needed.
2. Verify that the gasket is properly placed onto the closure and fully seated against the closure flange. Install or adjust the gasket if required and ensure that the gasket surfaces are free of defects or debris.
3. Start the bung plug into the container neck by hand, turning clockwise until the threads have engaged.
4. Use the manual or mechanical Torque Wrench and Torque Wrench Fitting as described above to finish seating the closure to the recommended torque (see Closure Application table).

CLOSURE APPLICATION			
CLOSURE STYLE	GASKET	SPECIFIC GRAVITY	TORQUE
Pressure Rating to 100 kPa			
Wolverine 2" Internal Buttress Plug, Vented	EPDM	1.4	20 Ft.-Lbs.
Pressure Rating to 150 kPa			
Wolverine 2" Internal Buttress Plug	EPDM	1.9	20 Ft.-Lbs.
Wolverine 2" Internal Buttress Plug	B4 Gasket	1.9	25 Ft.-Lbs.
Brandt 2" Internal Buttress Plug	EPDM	1.6	25 Ft.-Lbs.
Pressure Rating to 300 kPa			
Brandt 2" Internal Buttress Plug	EPDM	1.5	25 Ft.-Lbs.

63mm Crimp-On Fitting Closure Instructions

PURPOSE:

These instructions are designed to ensure the proper installation of any one of several 63mm crimp-on fittings onto BWAY jerricans and tighthead drums. The UN Regulated Container Certification applies to marked UN 1H1 and 3H1 Tight Head packages that are closed per this procedure.

SIGNIFICANCE:

The sealing performance of the UN components can be compromised if the components have been damaged in shipment or handling. Ensure that the crimp bead around the top of the container neck is clean and free of burrs, ragged edges, or other defects and verify that the inner surface of the fitting is clean and defect free before assembling the components.

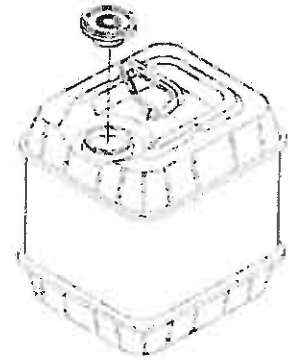

APPARATUS:

- o Manual or automatic multi-jaw crimp head (manual model shown in instruction diagrams)

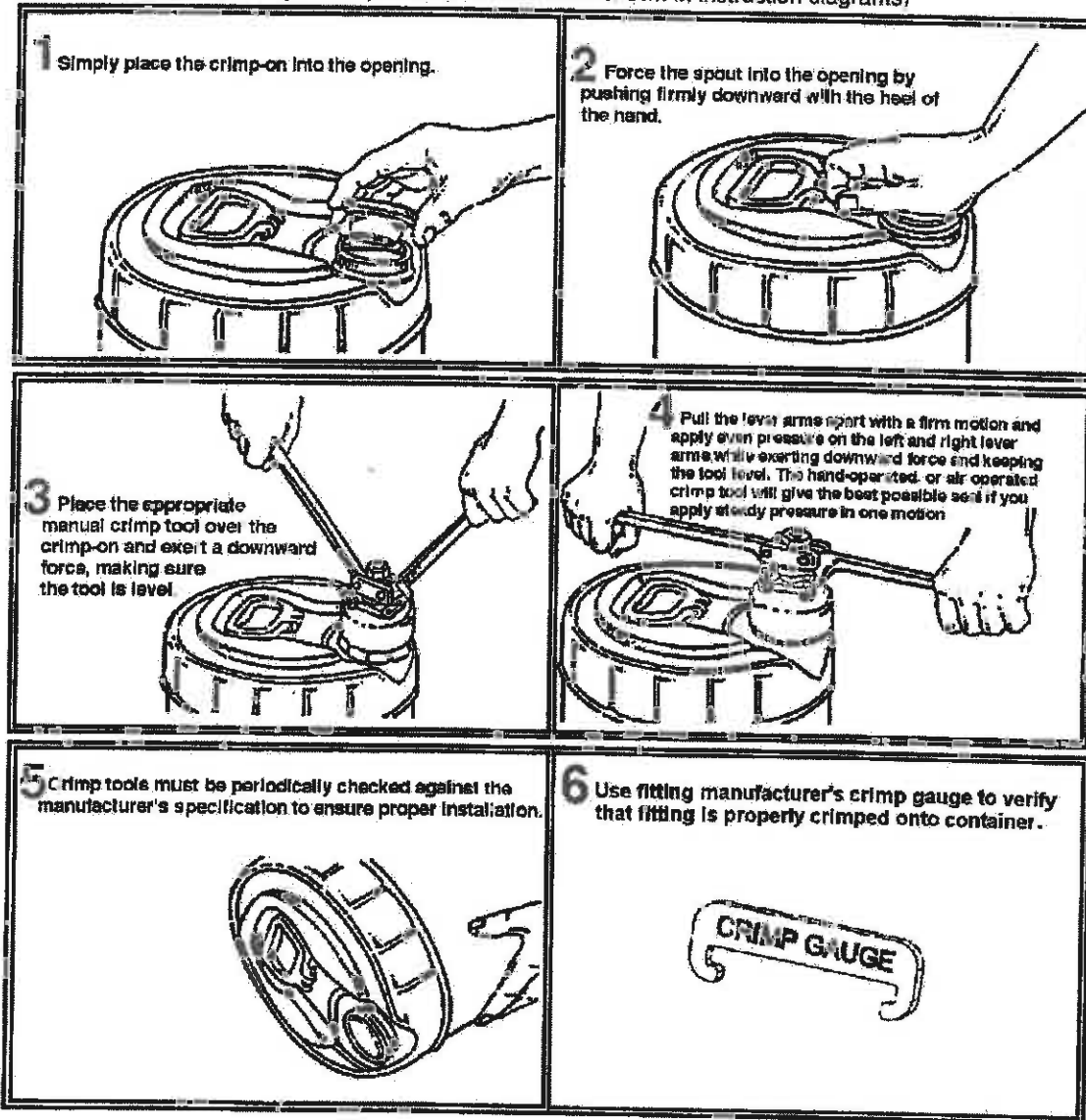

3/4" NPS Bung Plug Closure Instructions

PURPOSE:

These instructions are designed to ensure the proper installation of any one of several vented and non-vented 3/4" NPS threaded bung plugs into the vent orifice on BWAY jerricans and tighthead drums.

SIGNIFICANCE:

The UN Regulated Container Certification applies to marked UN 1H1 and 3H1 Tight Head packages that are closed properly, as per this procedure. Failure to follow this procedure may render the UN certification null. The sealing performance of the UN components can be compromised if the components have been damaged in shipment or handling and all components should be inspected prior to cover application.

APPARATUS:

- o Torque wrench of suitable measuring capacity (25 ft-lbs minimum), digital breakaway style preferred
- o Torque Wrench Fitting specific to the bung plug being installed. Fitting should be shape matched to and fit securely inside the center impression in the bung plug and mount directly to the torque wrench shaft. Contact the specific bung plug manufacturer for additional Torque Wrench Fitting information.
- o The use of a calibrated automatic torque application machine is permissible if it does not damage the threads or seating surface of the container.

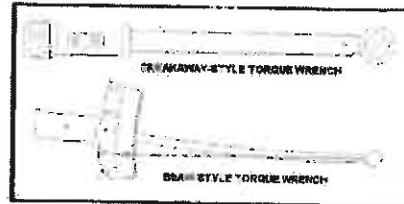

ASSEMBLY INSTRUCTIONS:

1. Verify that the top sealing surface of the container vent is clean and free of defects or debris. Clean as needed.
2. Verify that the gasket is properly placed onto the closure and fully seated against the closure flange. Install or adjust the gasket if required and ensure that the gasket surfaces are free of defects or debris.
3. Start the vent plug into the container neck by hand, turning clockwise until the threads have engaged.
4. Use the manual or mechanical Torque Wrench and Torque Wrench Fitting as described above to finish seating the closure to the recommended torque (see **Plug Installation Torque** table below).

Vent Plug Type	Installation Torque
3/4" Standard Bung Plug	85 in-lbs (7 ft-lbs)
3/4" Bung Plug with Membrane	85 in-lbs (7 ft-lbs)
3/4" Vented ACORN Bung Plug	85 in-lbs (7 ft-lbs)

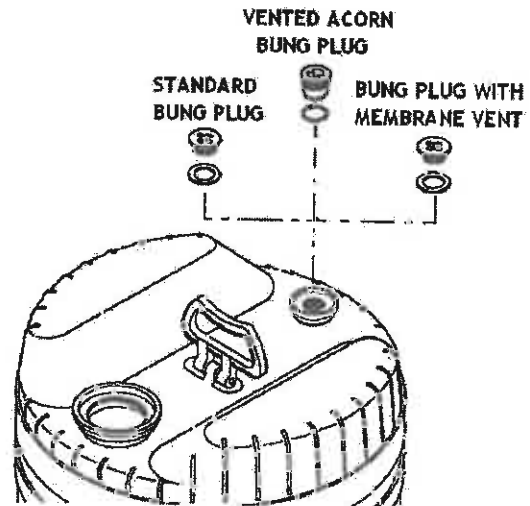

18, 22 and 28mm Screw Cap Vent Closure Instructions

PURPOSE:

These instructions are designed to ensure the proper installation of 18, 22 and 28mm screw caps onto their respective threaded vent openings on BWAY jerricans and tighthead drums. The UN Regulated Container Certification applies to marked UN 1H1 and 3H1 Tight Head packages that are closed per this procedure.

SIGNIFICANCE:

The sealing performance of the UN components can be compromised if the components have been damaged in shipment or handling and all components should be inspected prior to cover application.

APPARATUS:

- Torque wrench of suitable measuring capacity (25 ft-lbs minimum), digital breakaway style or T-Handle preferred.
- Torque Wrench Head Fixture specific to the screw cap being installed. Wrench Head should be shape matched and fitted securely to the outer diameter of the screw cap and mount directly to the torque wrench shaft. Contact the specific screw cap manufacturer for additional Wrench Head Fixture information.

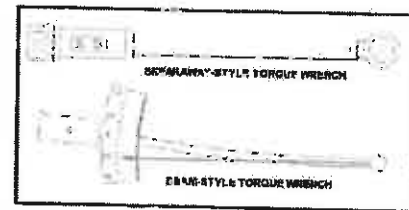

ASSEMBLY INSTRUCTIONS:

1. Verify that the top sealing surface of the container vent is clean and free of defects or debris. Clean as needed.
2. Verify that the gasket is properly placed inside the closure and fully seated against the closure's top inner surface. Install or adjust the gasket if required and ensure that the gasket surfaces are free of defects or debris.
3. Start the screw cap onto the container neck by hand, turning clockwise until the threads have engaged.
4. Use the manual or mechanical Torque Wrench and Torque Wrench Fitting as described above to finish seating the closure to the recommended torque (see Closure Application Torque table below).



Screw Cap Size	Application Torque
18mm SP400	15 in-lbs (1.3 ft-lbs)
22mm SP400	20 in-lbs (1.6 ft-lbs)
28mm SP400	25 in-lbs (2.0 ft-lbs)

CLOSURE TOOL REFERENCE TABLE

Closure Mfg'r	Closure Types	Closure Size (mm)	Closure Tool Model	Closure Tool Description
Various	Vent Caps	18, 22, 28		T-Handle Torque wrench
American Flange	Tri-Sure Tab Seal		UG	Manual Crimping Tool
	Tri-Sure Uni-Grip		UAG	Pneumatic Crimping Tool
Norpak / Norton	Norcap	70		Seekonk Torque Wrench (Gauge) or Equivalent with Rieke Cap Wrench Adapter, W394, or contact your Norpak/Norton representative for equivalent adapter
	Norcap Vented			
Republic	Comack	70		Seekonk Torque Wrench (Gauge) or Equivalent with Rieke Cap Wrench Adapter, W394, or contact your Republic representative for equivalent adapter
	Comack TEXT			
	SC63R Vented			
Brandt (BWAY)	Brandt 70mm Brandt 70 Vented Brandt 70mm TE	70		Seekonk Torque Wrench (Gauge) or Equivalent with Rieke Cap Wrench Adapter, W394, or contact your BWAY representative for equivalent adapter
Brandt (BWAY)	Brandt 61mm Brandt 61 Vented Brandt 61mm TE	61		Seekonk Torque Wrench (Gauge) or Equivalent with Rieke Cap Wrench Adapter, W394, or contact your BWAY representative for equivalent adapter
Westphal Lange	Westphal Lange 61mm TE	61		Seekonk Torque Wrench (Gauge) or Equivalent with Rieke Cap Wrench Adapter, W394; or contact your BWAY representative for equivalent adapter
Brandt (BWAY)	Brandt 51mm Vented	51		Seekonk Torque Wrench (Gauge) or Equivalent with Rieke Cap Wrench Adapter, W394; or contact your BWAY representative for equivalent adapter
Rieke	FS-60	70		Seekonk Torque Wrench (Gauge) or Equivalent with Rieke Cap Wrench Adapter, W394
	FS-70			
	FS-70 TE			
	FS-70 Vented			
	SC-76			
	SC-76 TE			
	FS-80			
	FS-80 TE FS-80 Vented			
SC-86 SC-86 TE				
Rieke/Bomag/Technocraft Pour Spouts	FS-10-6-300 FS-10-6-624 FS-10-8V-300 FS-300 FS-II		FS-600 IA-FS-600 HFS-600	Manual Flexspout Crimping Tool Airmatic Flexspout Crimping Tool Airdraulic Flexspout Crimping Head and Hose
	Bomag Crimp-on		FS-600 IA-FS-600 HFS-600	Manual Flexspout Crimping Tool Airmatic Flexspout Crimping Tool Airdraulic Flexspout Crimping Head and Hose
	Technocraft Crimp-on		FS-600 IA-FS-600 HFS-600	Manual Flexspout Crimping Tool Airmatic Flexspout Crimping Tool Airdraulic Flexspout Crimping Head and Hose

Many Torque Wrench Heads are custom made to suit a particular brand of closure. If you do not see yours listed on the chart above, please contact your BWAY sales representative who can help you source one for your particular application.

BWAY CORPORATION - LOCATIONS

ENGINEERING AND TECHNICAL SERVICES (Compliance Office):

6049 Guion Road
Indianapolis, IN 46254
317-308-4092

MANUFACTURING SITES:

UTAH:

1033 North Production Road
Cedar City, UT 84721
435-865-1992 M-5622

GEORGIA:

98 Amlajack Blvd
Newnan, GA 30265
678-423-2935

6134 Industrial Blvd.
Toccoa, GA 30577
706-886-7414 M-4201

2160 Lithonia Industrial Blvd.
Lithonia, GA 30058
770-482-7318 M-4367

INDIANA:

6061 Guion Road
Indianapolis, IN 46254
317-308-4075 M-4200

4002 Montdale Dr.
Valparaiso, IN 46383
219-462-8915 M-4604

NEW JERSEY:

7 Wheeling Rd.
Dayton, NJ 08810
609-860-0337 M-4202

PUERTO RICO:

Road 172 km 13.4
Cidra, PR 00739
787-739-7401 M-4198

TEXAS:

1591 Harvey Mitchell Parkway
Bryan, TX 77803-1182
979-779-5900 M-4199

For more information on BWAY, visit website at: www.bwaycorp.com